

# FANUC Robot M-410iB/700

## Operating space

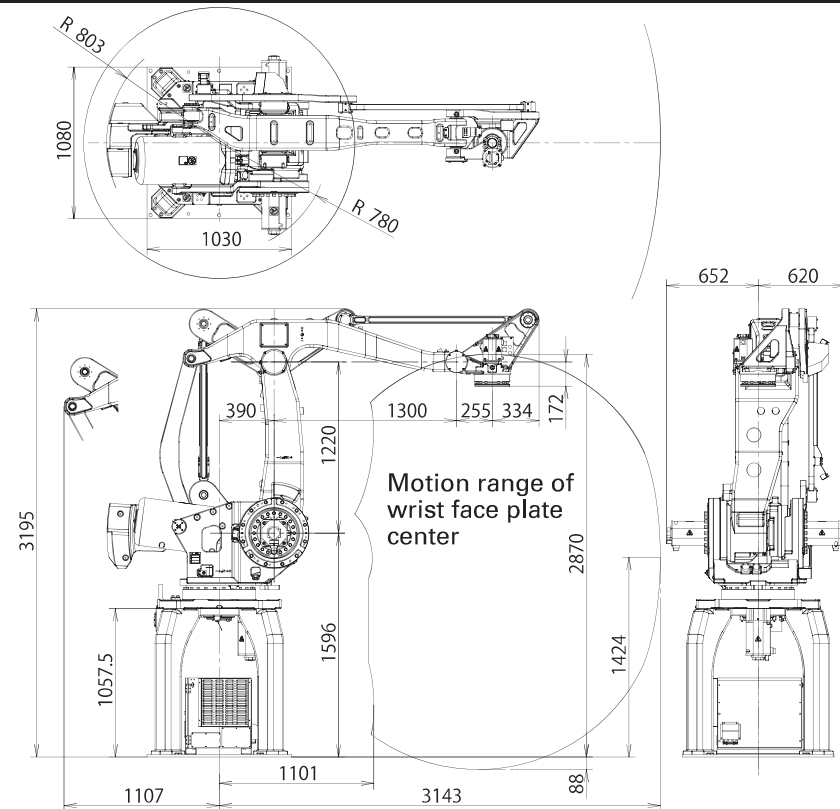

## Specifications

Item		Specifications
		M-410iB/700
Type		Articulated Type
Controlled axes		4 axes (J1,J2,J3,J4)
Reach		3.14m
Installation		Floor
Motion range (Maximum speed) (Note1)	J1 axis rotation	360° ( 60°/s) 6.28 rad (1.05 rad/s)
	J2 axis rotation	144° ( 60°/s) 2.51 rad (1.05 rad/s)
	J3 axis rotation	136° ( 60°/s) 2.37 rad (1.05 rad/s)
	J4 axis rotation	540° (120°/s) 9.42 rad (2.09 rad/s)
Max. load capacity at wrist		Max.700 kg
Allowable load inertia at wrist		490 kg · m <sup>2</sup> 5000 kgf · cm · s <sup>2</sup>
Throughput (Note2)		700 cycles/hour
Drive method		Electric servo drive by AC servo motor
Repeatability		± 0.5 mm
Mass (Note3)		2700 kg
Installation environment		Ambient temperature : 0~45°C Ambient humidity : Normally 75%RH or less (No dew, nor frost allowed) Short term Max. 95%RH or less (within one month) Vibration : 0.5G or less

Note 1) In case of short distance motion, the axis speed doesn't reach maximum one.

Note 2) With maximum payload, the horizontal range is 2000mm and vertical one is 400mm.

Note 3) Controller mass (120kg) is included.

## Intelligent palletizing robot

# FANUC Robot M-410iB



## Features

- The M-410iB series is the ideal intelligent solution for automation of palletizing systems.
- The wide range of M-410iB robot variations make it suitable for any application and payload.
  - FANUC Robot M-410iB/140H  
140kg payload, high speed type
  - FANUC Robot M-410iB/160  
160kg payload, high speed type
  - FANUC Robot M-410iB/300  
300kg payload, heavy payload type
  - FANUC Robot M-410iB/450  
450kg payload, heavy payload type
  - FANUC Robot M-410iB/700  
700kg payload, super heavy payload type
- The M-410iB robot series comes iRVision ready and can be programmed and simulated through ROBOGUIDE.
  - Detection of height of workpieces
  - Discrimination of a part size or type
  - Visual inspection
  - Sorting of workpieces
  - Depalletizing the load on a received pallet
  - Easy to create a palletizing program
  - Motion optimization of a program

## Application Systems



Box Palletizing



Bag Palletizing

# FANUC

FANUC AMERICA CORPORATION  
3900 WEST HAMLIN ROAD  
ROCHESTER HILLS MI 48309-3253



MARKETING@FANUCAMERICA.COM FANUCAMERICA.COM 888-FANUC-US

© 2014 FANUC America Corporation. All Rights Reserved.

FANUC LITHO IN U.S.A. FRA - 2/24/2014

# FANUC Robot M-410iB/140H, 160, 300, 450

## Operating space ( M-410iB/140H )

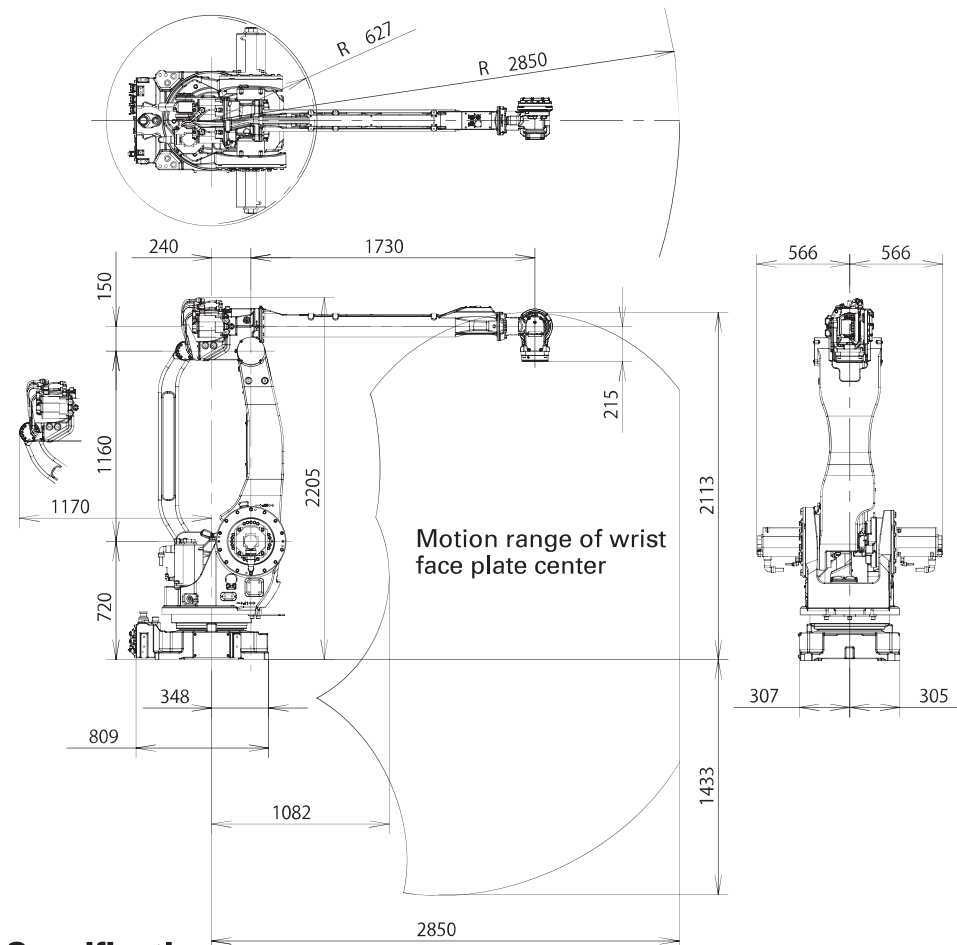

### Specifications

Item		Specifications	
		M-410iB/140H	
Type		Articulated Type	
Controlled axes		5 axes (J1,J2,J3,J4,J5)	
Reach		2.85m	
Installation		Floor	
Motion range (Maximum speed) (Note1)	J1 axis rotation	360° (140°/s)	6.28 rad (2.44 rad/s)
	J2 axis rotation	155° (115°/s)	2.71 rad (2.01 rad/s)
	J3 axis rotation	112° (135°/s)	1.95 rad (2.36 rad/s)
	J4 axis wrist swing(Note2)	20° (135°/s)	0.35 rad (2.36 rad/s)
	J5 axis wrist rotation	720° (420°/s)	12.57 rad (7.33 rad/s)
Max. load capacity at wrist		Max. 140kg	
Max. load capacity at J2 base		550kg	
Max. load capacity at J3 arm (Note3)		140kg	
Allowable load inertia at wrist	J4 axis	147 kg · m <sup>2</sup>	1500 kgf · cm · s <sup>2</sup>
	J5 axis	53 kg · m <sup>2</sup>	540 kgf · cm · s <sup>2</sup>
Throughput (Note4)		1900 cycles/hour	
Drive method		Electric servo drive by AC servo motor	
Repeatability		± 0.2 mm	
Mass (Note5)		1,200 kg	
Installation environment		Ambient temperature : 0~45°C Ambient humidity : Normally 75%RH or less (No dew, nor frost allowed) Short term Max. 95%RH or less (within one month) Vibration : 0.5G or less	

Note 1) In case of short distance motion, the axis speed doesn't reach maximum one.

Note 2) The wrist interface is always toward to downward. The angle is variable up to 20 degrees width.

Note 3) Max. payload capacity at wrist are changed by wrist load.

Note 4) With 45kg payload, the horizontal range is 2000mm and vertical one is 400mm. (with fan option)

Note 5) Without controller

## Operating space ( M-410iB/160, M-410iB/300 )

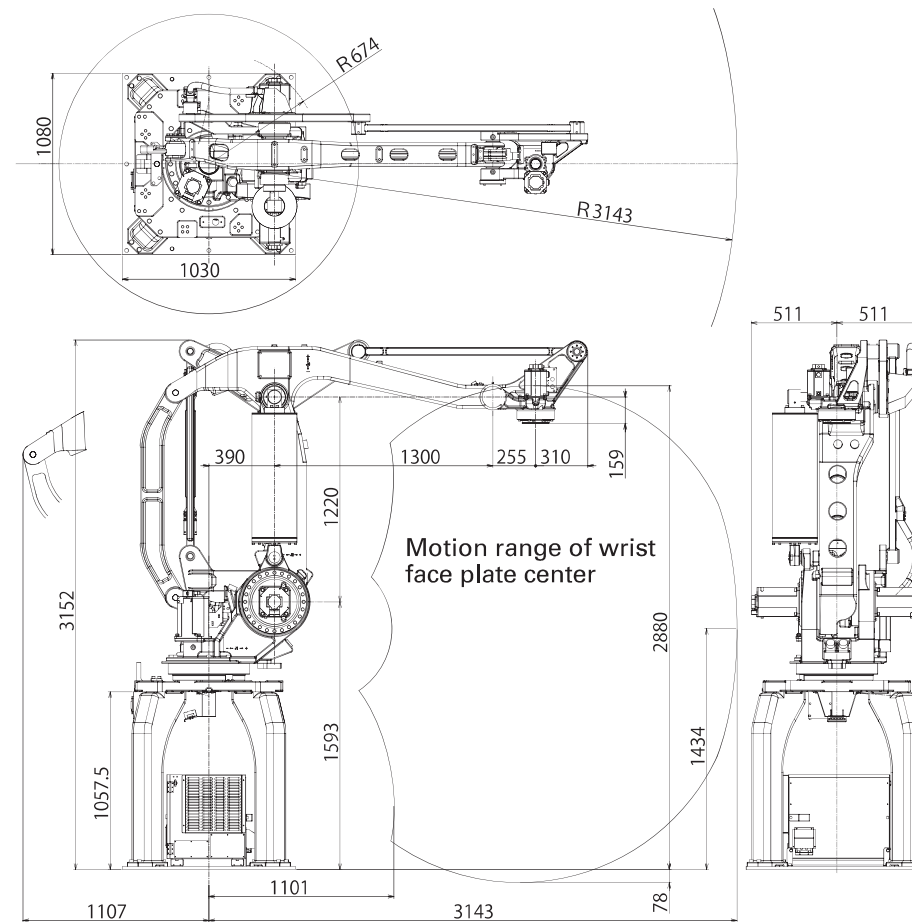

### Specifications

Item		Specifications	
		M-410iB/160	M-410iB/300
Type		Articulated Type	
Controlled axes		4 axes (J1,J2,J3,J4)	
Reach		3.14m	
Installation		Floor	
Motion range (Maximum speed) (Note1)	J1 axis rotation	360°(130°/s) 6.28 rad (2.27 rad/s)	360°(85°/s) 6.28 rad (1.48 rad/s)
	J2 axis rotation	144°(130°/s) 2.51 rad (2.27 rad/s)	144°(90°/s) 2.51 rad (1.57 rad/s)
	J3 axis rotation	136°(135°/s) 2.37 rad (2.36 rad/s)	136°(100°/s) 2.37 rad (1.75 rad/s)
	J4 axis rotation	540°(300°/s) 9.42 rad (5.24 rad/s)	540°(190°/s) 9.42 rad (3.32 rad/s)
	Max. load capacity at wrist		Max.160 kg
Allowable load inertia at wrist		78 kg · m <sup>2</sup> 800 kgf · cm · s <sup>2</sup>	137 kg · m <sup>2</sup> 1400 kgf · cm · s <sup>2</sup>
Throughput (Note2)		1500 cycles/hour	1000 cycles/hour
Drive method		Electric servo drive by AC servo motor	
Repeatability		± 0.5 mm	
Mass (Note3)		1940 kg	
Installation environment		Ambient temperature : 0~45°C Ambient humidity : Normally 75%RH or less (No dew, nor frost allowed) Short term Max. 95%RH or less (within one month) Vibration : 0.5G or less	

Note 1) In case of short distance motion, the axis speed doesn't reach maximum one.

Note 2) With maximum payload, the horizontal range is 2000mm and vertical one is 400mm.

Note 3) Controller mass (120kg) is included.

## Operating space ( M-410iB/450 )

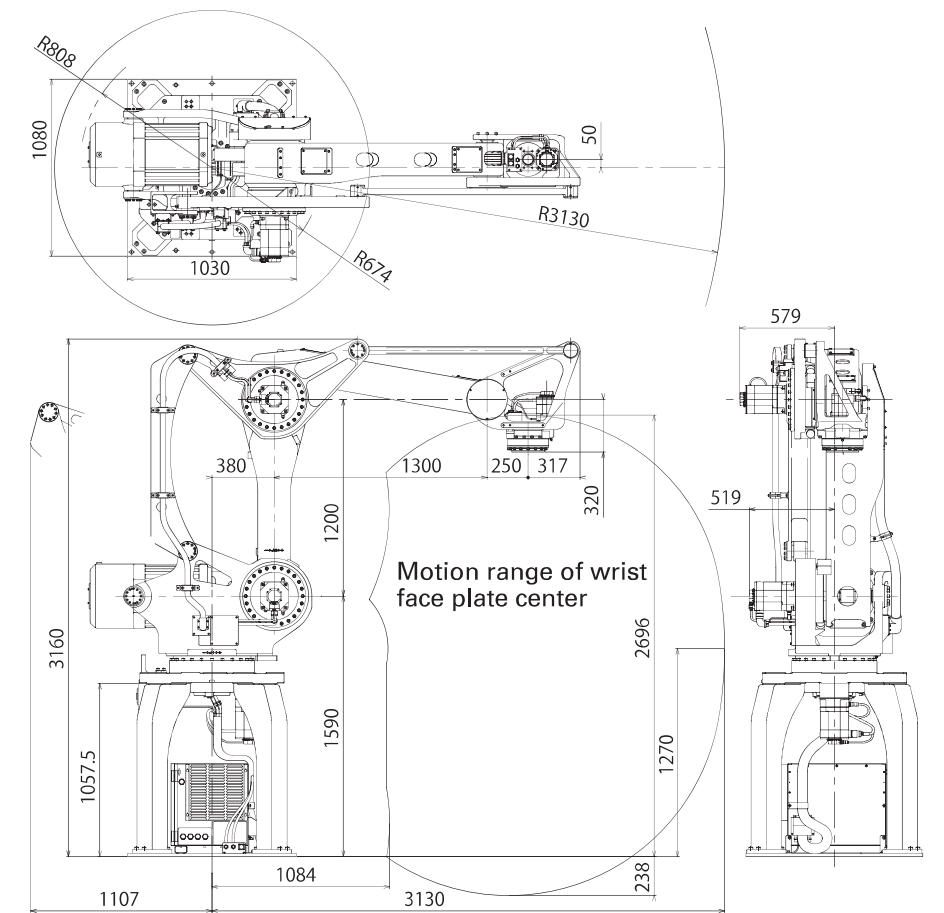

### Specifications

Item		Specifications	
		M-410iB/450	
Type		Articulated Type	
Controlled axes		4 axes (J1,J2,J3,J4)	
Reach		3.13m	
Installation		Floor	
Motion range (Maximum speed) (Note1)	J1 axis rotation	360°(70°/s) 6.28 rad (1.22 rad/s)	360°(70°/s) 6.28 rad (1.22 rad/s)
	J2 axis rotation	145°(70°/s) 2.53 rad (1.22 rad/s)	145°(70°/s) 2.53 rad (1.22 rad/s)
	J3 axis rotation	135°(70°/s) 2.36 rad (1.22 rad/s)	135°(70°/s) 2.36 rad (1.22 rad/s)
	J4 axis rotation	540°(180°/s) 9.42 rad (3.14 rad/s)	540°(180°/s) 9.42 rad (3.14 rad/s)
	Max. load capacity at wrist		Max.450 kg
Allowable load inertia at wrist		196 kg · m <sup>2</sup> 2000 kgf · cm · s <sup>2</sup>	
Throughput (Note2)		700 cycles/hour	
Drive method		Electric servo drive by AC servo motor	
Repeatability		± 0.5 mm	
Mass (Note3)		2430 kg	
Installation environment		Ambient temperature : 0~45°C Ambient humidity : Normally 75%RH or less (No dew, nor frost allowed) Short term Max. 95%RH or less (within one month) Vibration : 0.5G or less	

Note 1) In case of short distance motion, the axis speed doesn't reach maximum one.

Note 2) With maximum payload, the horizontal range is 2000mm and vertical one is 400mm.

Note 3) Controller mass (120kg) is included.